



The number one intelligent bus based control system for smart houses and buildings

The intelligent building control system

Control your building or home from ANYWHERE in the world

A totally **scalable solution**, whether you install it in your home, an office, a factory or a hotel.

Local or remote management

InfoControl allows you to manage your installation either via a PC or remote control in your own premises, or you can communicate securely with the PC from any location worldwide that has access to the Internet or GSM text message service.



Voice activation is also possible using a microphone !

Intelligent switching

- Reduces your energy bill
- Controls any electrically powered device

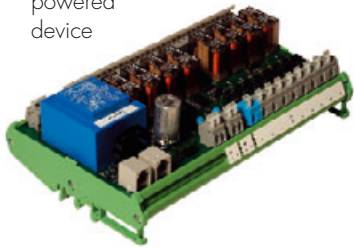

A full range of sensors:

- Infrared • Radar • Multifunction
- Temperature • Pressure • Humidity • Light (lux)
- Movement

The InfoControl system is the first fully **intelligent bus system** where each single sensor has its own microprocessor and all sensors are freely programmable. Each single sensor box can measure: temperature, movement, light incidence, pressure and humidity. A special radar sensor can be used to integrate advanced alarm functions using your building's power management.

Fully Microsoft Windows 95, 98, NT, 2000, XP compatible software opens a new frontier for controlling your home or business building from everywhere in the world. Manageable via Email, SMS, and easy to use interface and programming capabilities, opens up the door to the future of living. You may control thousands of devices like TV, VCR, DVD and basically all existing consumer devices.

Infrared controlled devices, wireless devices, alarm systems, heating and air condition plants and all other different types of electrical appliances can be easily attached and controlled by the system.

Save Energy, reduce Costs



InfoControl is a Swiss made «state of the art» building control system. The highest quality and security requirements have been applied to match international standards.

The development of the system has taken over 9 years and it has been tested in real life conditions in houses, buildings and offices during its development.

The INFOCONTROL team is now proud to announce its technology to the world markets and wants to thank all the engineers, companies and individuals that have contributed to make it real.

We are proud to announce the first easy-to-deploy bus system that will open the access of «bus technology» to a broad range of installers and operators in the sector.

Full interoperability with existing standards or installations are – simple to implement

The system is fully scalable from controlling a single room up to large buildings, like shopping centres, offices, public buildings or airports.

It's 4 wire bus is about 20 times faster than most of the competing last generation bus systems. Additionally it provides full intelligence by deploying a «state of the art» software solution that has taken over the functions of many «non intelligent» components which reduces the hardware complexity and increases reliability of the system. Remote monitoring

and in programming functions are built-in as standard features and require no additional hardware.

InfoControl is the first intelligent system that may be deployed by electricians without specific training and experience.

InfoControl is the first bus system where each element has an incorporated microprocessor and may be remotely updated.

InfoControl is the first bus system that can be entirely programmed over the Web.

InfoControl is the first bus system based on just a couple of components that are fully intelligent.

InfoControl is the first system enabling you to plan and build quickly complex smart buildings of any dimension.

InfoControl is the «state of the art» building control system that is affordable for everyone and that gives you access and security to your home from everywhere in the world.



Switchbox

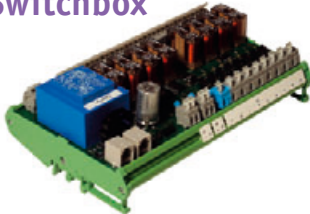

8 outputs: Each Relay 2000 VA - 8 Inputs 12-48 Volt or 110 Volt or 220 Volt - 2 potential free inputs - incorporated microcomputer and bus system.

Reduction of up to 50% of energy consumption.

Due to its intelligence, InfoControl will result in a significant reduction of your energy bill. Not only lights or HVAC applications may be controlled and benefit from this functionality, but virtually every electrical and electronic appliance may be addressed directly using the control bus, with infrared commands and other communication standards.

Infrared Sensor



The InfoControl INFRARED SENSOR can send and receive infrared signals to and from all IR enabled devices. It interacts with the InfoControl remote control and can transmit the signals over the bus to any location inside your building.

Communicate with all devices that are infrared compatible.

Television, DVD, SAT, IR - dimmers & switches, HiFi equipment, air conditioners and virtually every device that is remote controlled by IR will now be integrated in your «smart building». You will be able to control all this even from the other side of the world. It's up to your imagination.

Multifunction Sensor



This InfoControl SENSOR is able to measure temperature, pressure, light, humidity + IR movement. All this in just one device. All single functionalities are programmable for sensitivity.

The highest quality of components available on the market have been used to produce this masterpiece.

Incorporated microcomputer for highest flexibility.

Due to its onboard intelligence you can adapt the functionality of your sensors to virtually every situation. The sensors provide the system with the information about all the environmental conditions inside a room. Based on these multiple inputs the system takes actions that will transform the building's power network and devices in a «real intelligent» milieu.

Radar Sensor



This InfoControl SENSOR has been developed especially for high security applications and environments. It can penetrate concrete walls and measure movement even behind a wall.

Incorporated microcomputer for highest flexibility.

Due to its onboard intelligence you can adapt the functionality of your sensors to virtually every situation. The sensors provide the system with the information about all intruders or movement conditions inside a room. Based on these inputs the system takes actions that will secure your building. The sensor is able to calculate even the speed of an object approaching or moving in a opposite direction.

Converter & Software



PC to bus converter: Handles up to 256 sensors over the RS232 Com port of your PC. Connects your home or building to the PC and allows you to access it over Internet, send SMS, email and many other features. The converter includes the InfoControl software V3.0 that is compatible with Microsoft Windows 95, 98, ME, NT, 2000 and XP.

Program your home's functionality - a new way to perceive interactivity.

One converter can handle up to 256 modules. Additionally it feeds the bus with low voltage (48 Volts). The converter can work without being connected to the PC. All the system setup and functionalities are transferred to the onboard microcomputer of each single sensor, switchbox, or module. In case of a PC crash the system remains fully programmed as it was before the event and may be operated with or without physical switches. **INFOCONTROL DOES NOT NEED A COMPUTER TO WORK** – only exceptions are infrared, Web and mail based services. This unique feature gives it the reliability to be deployed in environments where stability is a must.

Other accessories available:

- Repeater unit
- Remote control
- Wall switch module
- Keyboard

Copyright notice:

Website and content: Copyright 2001, 2002 INFOBYTE AG*Microsoft is a trademark from Microsoft Incorporation *INFOCONTROL is a trademark from Infobyte AG.

Technical specifications are subject to change without prior notice.



The number one intelligent bus based control system for smart houses and buildings

Switchbox

Managed switching... ahead of its time!

The heart of the InfoControl system

The **switchbox** reacts to the parameters you have set to manage conditions in your home or building.

Inputs from sensors are compared with the «states» you have defined and the switchbox relays will be energised accordingly.

The **switchbox** contains :

- 8 outputs - switched via a relay 2000VA each
- 8 inputs 12-48 Volt or 110 Volt or 220 Volt
- 2 potential free inputs
- Incorporated microcomputer and bus system.

Due to its innovative architecture and programmable capabilities, you can easily add 3rd party components and switches.

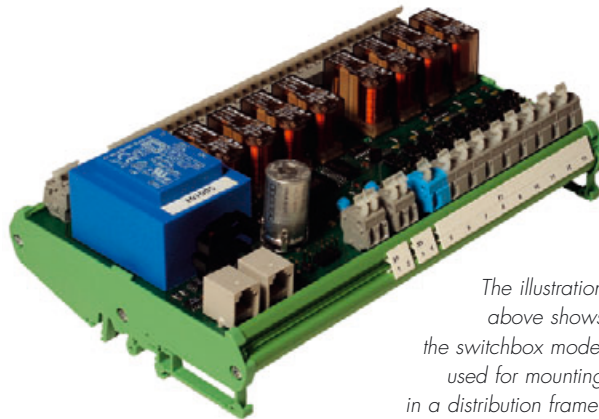

The illustration above shows the switchbox model used for mounting in a distribution frame. (Max. load 10A).

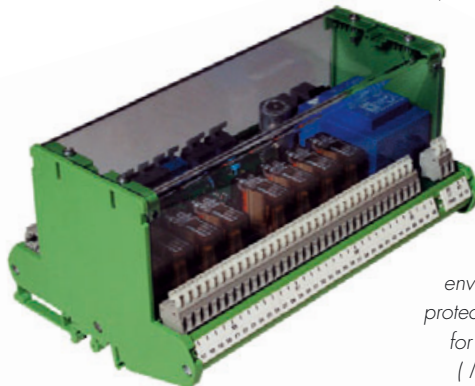

Also available is a covered version (left) which can be used in an environment where protection is required for safety reasons. (Max. load 6A)

Although you will establish the working parameters using the **InfoControl** software on your PC, you will not need the PC to be switched on all the time unless you have multiple PC bus converters, infrared devices, Web and mail based services.

All the system setup and functionalities are transferred to the onboard microcomputer of each single sensor, switchbox, or module.

In case of a PC crash the system remains fully programmed as it was before the event and may be operated about the physical switches.

This unique feature gives it the reliability to be deployed in environments where stability is a must.

Features

Intelligent messaging

The **switchbox** can be programmed to alert you when any number of events occur. If the temperature goes above normal and the air conditioning is not adequate, or a radar sensor is tripped, the switchbox will alert the **InfoControl** software. You can choose whether to be notified via an SMS text message, Email, voice mail to your mobile phone, or a message to a pager.

The possibilities are infinite.

Remote programming

The preset parameters in the **switchbox** can be changed «on the fly». You can update how the inputs and outputs react, and how they are assigned via the Internet, your mobile phone sending an SMS or via an answering machine.

Flexibility at your fingertips.

Relay management

The **switchbox** activates devices attached to it via relays. How the relays react is based on instructions from timers, inputs and sensors.

The relays can act as monostable or time based (i.e. on for 5 minutes, off for 10 minutes).

They can be programmed to act as a group, with preset intervals between switching on a load to prevent exceeding current limits. Relays can be programmed to have delays, and support autoreverse functions.

Infrared interface

The switching of devices attached to the **switchbox** can be controlled via an Infrared remote control. You can activate or deactivate devices in any part of a building from a central point using pre-programmed sequences of commands.

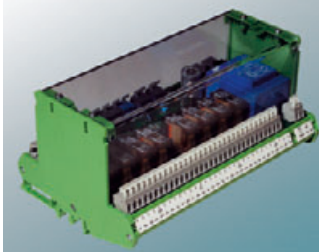

Switchbox

■ Electrical connections	8 switched outputs (120V or (240V), 8 isolated inputs (12-48V or 110-220V) , 2 passive inputs
■ Power source	120V or 240V
■ Max. load (Amps)	10A (frame mounted version) 6A enclosed version
■ Power consumption	7,5W / 35mA
■ Environmental	Normal operating temperature: -10°C to +40°C. Relative humidity 90%
■ Connectors	Two RJ12 connectors for control bus
■ Indicators	Status LED, power LED, relay status LED (1 per relay), input LED (1 per input)

For further information:

InfoByte AG
Binzenholzstrasse 451
CH-5704 Egliswil

Switzerland

Tel. +41 (0)62 769 87 00
Fax +41 (0)62 769 87 90

info@infocontrol.com

Visit our Website
www.infocontrol.com

Visiting us?



Egliswil is located about 30 minutes from Zürich Airport direction Bern/Basel.

Copyright notice:

Website and content: Copyright 2001, 2002 INFOBYTE AG*Microsoft is a trademark from Microsoft Incorporation *INFOCONTROL is a trademark from Infobyte AG.

Technical specifications are subject to change without prior notice.



The number one intelligent bus based control system for smart houses and buildings

Wall switch module

Full compatibility with 3rd party vendors

Control up to 60 switches with a single wall switch panel

You can use the InfoControl wall switch panel to control up to 60 functions performed by traditional switches. Use our standard switches or integrate with 3rd party vendors, like Clipsal, BTicino, Siemens, or other switch manufacturers.

Devices that are to have their loads switched using the wall switch module must be connected via a switchbox.

The InfoControl switch module is built to handle up to 16 low voltage physical switches. The physical switches can be «layered» to provide 4 logical levels, each of which can be individually programmed.

Programming of the switches and states of the LED's is achieved using the InfoControl management software. LED's indicate the state of each switch.

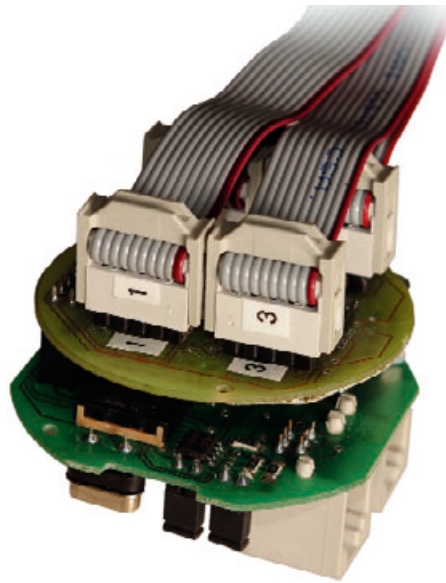

The wall switch control module with onboard microcomputer.

If you have existing switches, these too can be integrated with the module. We have chosen one set that matches optically with the design of our sensors, but you are free to integrate it with thousands of different designs and standards.

The switch module is attached with a flat band cable to the control module. Additionally to the 16 possible inputs the module provides 16 outputs for LED's that are independently programmable to indicate the actual status of the switches.



Example switch panel configurations

Features

- **Logical switch layers** A single physical switch panel can be defined as four logical layers. Removes the need to purchase unnecessary switch hardware.
- **3rd party switches** Switch module will support 3rd party wall switches connected by flat (ribbon) cable.
- **Programmable** Program the functionality using InfoControl management software. Determine switch status by LED display.



Switch Module

■ Electrical connections	None
■ Power source	48V from control bus
■ Max. load (Amps)	n/a
■ Power consumption	0,5W / 10mA
■ Environmental	Normal operating temperature -10°C to +40°C. Relative humidity 90%
■ Connectors	Two RJ12 connectors for control bus. Four 10-pole ribbon cable connectors
■ Connectivity	Maximum of 16 physical switches in groups of 4. Up to 60 switches can be configured. If using «logical» layers, one switch is reserved for layer switching.
■ Indicators	Red status LED on switch module

For further information:

InfoByte AG
Binzenholzstrasse 451
CH-5704 Egliswil

Switzerland

Tel. +41 (0)62 769 87 00
Fax +41 (0)62 769 87 90

info@infocontrol.com

Visit our Website
www.infocontrol.com

Visiting us?



Egliswil is located about 30 minutes from Zürich Airport direction Bern/Basel.

Copyright notice:

Website and content: Copyright 2001, 2002 INFOBYTE AG*Microsoft is a trademark from Microsoft Incorporation *INFOCONTROL is a trademark from Infobyte AG.

Technical specifications are subject to change without prior notice.



The number one intelligent bus based control system for smart houses and buildings

Infrared Sensor

Single IR interface

One remote control for everything

Whether you are using InfoControl at home or in a commercial environment, imagine only having a single remote control that will perform all the functions of all your other «remote's» rolled into one.

No more do you need to have many remote controls to control devices, and what is more you can send signals to any IR controllable device in your building from any location in that building that has an **infrared sensor** installed.

You simply «learn» the signals from all your remote controls, and store them in the **InfoControl** database.

Once stored, you then associate the commands with buttons on your InfoControl multipurpose remote control.

The database delivered with InfoControl management software also contains an extensive library of devices and their associated IR signals.

You can also combine multiple commands together using macros. A single push of a button can send one or more commands to different devices.



InfoControl remote



Infrared keyboard

Going one step further, the InfoControl remote can be used to control non IR controllable devices by sending command sequences to one or more **switchboxes**.

The possibilities are endless.

Television, DVD, SAT, IR - dimmers & switches, HiFi equipment, air conditioners and virtually every device that is remote controlled by IR will now be integrated in your «smart building». You will be able to control all this even from the other side of the world. It's up to your imagination.

You can also use an IR keyboard in association with the IR module.

Features

- **Learning**
A single infrared module will be designated as the «learning» device in your installation. This sensor will be used to capture signals from any remote control you wish to integrate into the system.
- **Reception indicator**
How many times have you wondered if the remote control is sending a signal or not? The infrared sensor visually advises you that it has received a signal by an LED that flashes to acknowledge receipt.
- **Signal types**
The signal standards recognised by the infrared module are RC5, Phillips, B&O, Beam-It.



Infrared Sensor

■ Electrical connections	None
■ Power source	48V from control bus
■ Max. load (Amps)	n/a
■ Power consumption	0,5W / 10 mA
■ Environmental	Normal operating temperature: -10°C to +40°C. Relative humidity 90%
■ Connectors	Two RJ12 connectors for control bus
■ Demodulators	Temic or Sharp
■ Range	Typically 5 – 10m dependant on positioning of module. Exposure to strong sunlight may reduce effective range.
■ Indicators	Red status LED

For further information:

InfoByte AG
Binzenholzstrasse 451
CH-5704 Egliswil

Switzerland

Tel. +41 (0)62 769 87 00
Fax +41 (0)62 769 87 90

info@infocontrol.com

Visit our Website
www.infocontrol.com

Visiting us?



Egliswil is located about 30 minutes from Zürich Airport direction Bern/Basel.

Copyright notice:

Website and content: Copyright 2001, 2002 INFOBYTE AG*Microsoft is a trademark from Microsoft Incorporation *INFOCONTROL is a trademark from Infobyte AG.

Technical specifications are subject to change without prior notice.



The number one intelligent bus based control system for smart houses and buildings

Multifunction Sensor

Incorporated microcomputer for highest flexibility

One sensor. . . five functions

The **InfoControl** Multifunction Sensor module provides continuous monitoring of FIVE input modes simultaneously :

- Light
- Movement
- Pressure
- Temperature
- Humidity

All these values are reported back and monitored. Preset high / low limits are compared and when thresholds are exceeded, predefined actions automatically take place.

Each sensor mode is individually programmable for sensitivity.

In addition, when threshold events are triggered, these can result in notification by SMS, Email, pager etc being invoked.



One or more sensors can be connected to the control bus and are able to be averaged as a group before any action is taken.

The sensors provide the system with the information about all the environmental conditions inside a room or building. Based on these multiple inputs the system is able to perform actions that will control your building's power network or alert you of security events or threshold violations.



Features

- **Light**
Photometrics are measured in lux with very fast response times to changes in value. No calibration is required. Normal operating range is 0 – 10,000 lux.
- **Movement**
Movement is detected by the built-in infrared sensor. As it is infrared it reacts to heat differential in the room, and can sense the presence of a human moving at up to 5 metres. The arc angle of sensitivity for detection is 104° horizontal, and 30° vertical.
- **Pressure**
The pressure sensor returns its reading as a value expressed in Millibars (Mbar). Normal operating range is 150 – 1,150 Mbar. Displayed in Millibars or Psi.
- **Temperature**
The temperature sensor measures temperature in degrees Centigrade with a normal operating range from -30°C to +130°C. An option is present to connect an external temperature sensor if required, (if temperature <-10°C >+40°C). Can be displayed as either Centigrade or Fahrenheit.
- **Humidity**
Relative humidity readings are reported as a percentage (%).



Multifunction Sensor

■ Electrical connections	None
■ Power source	48V from control bus
■ Max. load (Amps)	n/a
■ Power consumption	0,5W / 10mA
■ Environmental	Normal operating temperature: -10°C to +40°C. Relative humidity 90%
■ Connectors	Two RJ12 connectors for control bus
■ Maximum operating limits	<ul style="list-style-type: none">• Light : 0 – 100,000 lux• Movement : Yes, no• Pressure : 0- 4,000 Mbar• Temperature: -50°C to + 150°C• Humidity: 0% to 100% Values exceeding these limits will cause damage to the module.
■ Normal operating limits	<ul style="list-style-type: none">• Light : 0 – 100,000 lux• Movement : Yes, no• Pressure 150 – 1,150 Mbar• Temperature: -30°C to + 130°C• Humidity: 5% to 95%
■ Indicators	Red status LED
■ Calibration	Factory calibrated before delivery

For further information:

InfoByte AG
Binzenholzstrasse 451
CH-5704 Egliswil

Switzerland

Tel. +41 (0)62 769 87 00
Fax +41 (0)62 769 87 90

info@infocontrol.com

Visit our Website
www.infocontrol.com

Visiting us?



Egliswil is located about 30 minutes from Zürich Airport direction Bern/Basel.

Copyright notice:

Website and content: Copyright 2001, 2002 INFOBYTE AG*Microsoft is a trademark from Microsoft Incorporation *INFOCONTROL is a trademark from Infobyte AG.

Technical specifications are subject to change without prior notice.



The number one intelligent bus based control system for smart houses and buildings

Radar Sensor

Incorporated microcomputer for highest flexibility

Is there anybody there ?

The **InfoControl** radar sensor module detects any form of movement in a room and can even penetrate concrete walls to alert you of unwanted intruders. (Note: Sensitivity subject to thickness of concrete and/or reinforcing mesh density or presence of steel armour).

The radar sensor will instantly report the event of movement and a predefined event will be triggered and the appropriate actions taken. Such action could include switching on lights, coupled with activation of a camera and VCR.



Most importantly, the fact that movement has taken place generally would indicate that a security violation has occurred, and appropriate alerts can automatically be sent out.

Features

- **Movement**
The radar module will detect movement in both directions relative to the sensor.
- **Alerts**
Instantaneous alerts can be programmed to be sent to you or your security controller, either by SMS text message, Email or pager.
- **Programmable reaction**
The system can be programmed to take one or more pre-programmed actions if movement is detected.



Radar Sensor

■ Electrical connections	None
■ Power source	48V from control bus
■ Max. load (Amps)	n/a
■ Power consumption	1,9W / 40mA
■ Enviromental	Normal operating temperature: -10°C to +40°C. Relative humidity 90%
■ Connectors	Two RJ12 connectors for control bus
■ Maximum operating limits	-20C - +60C. Values exceeding these limits will cause damage to the module.
■ Normal operating limits	-20°C to +60°C
■ Indicators	Red status LED
■ Calibration	None required

For further information:

InfoByte AG
Binzenholzstrasse 451
CH-5704 Egliswil

Switzerland

Tel. +41 (0)62 769 87 00
Fax +41 (0)62 769 87 90

info@infocontrol.com

Visit our Website
www.infocontrol.com

Visiting us?



Egliswil is located about 30 minutes from Zürich Airport direction Bern/Basel.

Copyright notice:

Website and content: Copyright 2001, 2002 INFOBYTE AG*Microsoft is a trademark from Microsoft Incorporation *INFOCONTROL is a trademark from Infobyte AG.

Technical specifications are subject to change without prior notice.



The number one intelligent bus based control system for smart houses and buildings

PC Converter and Software

Program your building's functionality

A new way to perceive interactivity

The PC converter is your interface between the **InfoControl management software** and your intelligent modules.

InfoControl management software stores all the information related to your installation in its database together with «instructions» on what to do and when.

When you change a parameter, or describe an event to which the modules should react, this information is transmitted and stored in onboard microcomputer of each switchbox, sensor or module using the control bus.

If the PC is «down» for whatever reason the system remains fully programmed and continues to run using the stored information. In short, **reliability and stability is guaranteed.**

Extensive logging capabilities provide you with a comprehensive audit trail of all the events that have taken place in your installation.



InfoControl software is compatible with Microsoft Windows 95, 98, ME, NT, 2000 and XP.

The **PC to bus converter** will handle up to 256 modules (switchboxes, sensor and wall switch). Each module has a specific hardware address.

The converter is connected to your PC using an RS232 COM port. It connects your home or building to the PC and allows you to access it over Internet, send SMS, email and many other features. If an event occurs, InfoControl will let you know about it, should you choose to be notified.

If you want to install more than 256 modules connected, you can add another converter (connected to another COM port). You can also install repeaters to increase distance or capacity.

The connectivity parameters are described in the technical specifications overleaf.

It is recommended that a UPS is installed to maintain power to the converter.

Build your smart house with the world's easiest to use building control system.

Each sensor and module has its own dedicated microcomputer onboard and can access internet and communication services.

Time and distance becomes meaningless. You can control your building or house from anywhere in the world, receive emails, messages, alarms, notifications and many other types of information.

Features

■ PC to bus converter

The interface between the InfoControl management software and the control modules it manages. Up to 256 modules can be managed by a single converter. Connected via RS232 cable to the PC COM port. Status LED's for power supply, control bus and internal processor.

■ Standalone

The PC bus converter will continue to function if the PC is inoperable for whatever reason.

■ Audit trail

InfoControl management software provides an audit trail of all activities that have occurred. Temperature changes, movement, light etc. See at a glance not only when it changes but the values too!



PC Converter and Software

Electrical connections	2,1mm external power source plug
Power source	48V Power supply
Power consumption	2,4W / 50mA
Environmental	Normal operating temperature: -10°C to +40°C. Relative humidity 90%
Connectors	Two RJ12 connectors for control bus
LED's	2 x red LED for bus processor function check. 2 x green LED for power supply
Connectivity	<ul style="list-style-type: none"> • A single PC bus converter can manage and control a maximum of 256 modules. • A PC bus converter must be attached to its own dedicated COM port on the PC. • If more than 256 modules are installed, 2 or more additional PC bus converters must be present, each connected to a dedicated COM port on the PC. • A PC bus converter can have a 1 or two strings attached. • The maximum number of modules on a single string is 32. • For example, a single converter with no repeaters, and two strings attached, can have a max. of 64 modules (32 on each string). The figure of 32 is derived from the max. current consumption allowed on the string. • Control bus cable distances also have an effect on the maximum number of modules that can be connected. You may require repeaters to be installed. (maximum length is 1 Km). • If one or more repeaters are used, a string can be expanded by a factor of 32 for each repeater, up to a maximum of 256.

Control bus cable limits The longer the segment is, the less modules can be attached due to electrical constraints. The table below indicates the maximum number of modules that can be attached relative to the length of the string or segment. Distances shown are in meters.

String length (m)	100	200	300	400	500	600	700	800	900	1000
Max. no modules	32	25	17	12	10	8	7	6	5	5

For further information:

InfoByte AG
 Binzenholzstrasse 451
 CH-5704 Egliswil

Switzerland

Tel. +41 (0)62 769 87 00
 Fax +41 (0)62 769 87 90
 info@infocontrol.com

Visit our Website
www.infocontrol.com



Visiting us?

Egliswil is located about 30 minutes from Zürich Airport direction Bern/Basel.

Copyright notice:

Website and content: Copyright 2001, 2002 INFOBYTE AG*Microsoft is a trademark from Microsoft Incorporation *INFOCONTROL is a trademark from Infobyte AG.

Technical specifications are subject to change without prior notice.



The number one intelligent bus based control system for smart houses and buildings

Repeater Module

Extend your capability...

If you intend to install the **Info Control** modules on a large campus, or office block, you may either exceed the distance limitations on a single control bus, or the number of devices that can be connected.

InfoControl provides a solution to this scenario by providing a **repeater** unit.

An installation will require one or more repeaters if connection of modules will exceed the cable connectivity limits. (A table is shown in the technical specifications section overleaf).

A repeater unit can be used to extend an existing bus segment by providing one or more subsegments.

The repeater also allows you to cascade devices on a segment or subsegment by providing the capability to connect a second string.

Each repeater segment will extend the managed module capacity by 32 modules per string. Two strings can be connected giving a total of 64 modules that can be connected.

The diagram to the right shows an example topology.



The total length of any segment cannot exceed 1km. This is the sum of all the strings in the sub segment.

*left
repeater module*

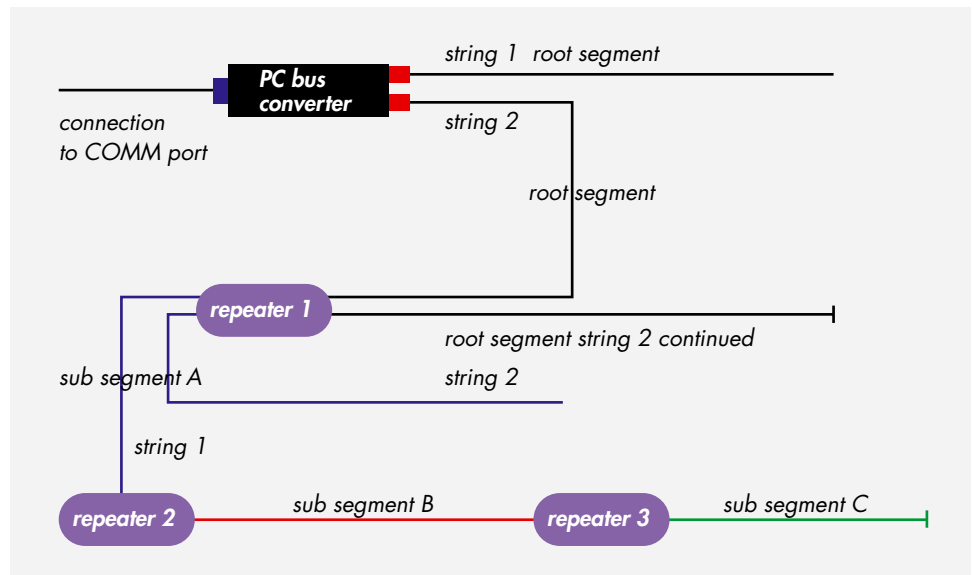

Features

- **Increases capacity** Add up to 64 additional InfoControl modules.
- **Increases distance** Overcome any distance constraints.
- **Flexibility** Easily accommodates your building or campus topology. Ensures you can install modules where you wish.



Repeater Module

■ Electrical connections	2,1mm external power source plug
■ Power source	48V Power supply
■ Power consumption	2,4W / 50mA
■ Environmental	Normal operating temperature: -10°C to +40°C. Relative humidity 90%
■ Connectors	Four RJ12 connectors for control bus
■ LEDs	2 x red LED for bus processor function check. 2 x green LED for power supply.
■ Control bus cable limits	The longer the segment is, the less modules can be attached due to electrical constraints. The table below indicates the maximum number of modules that can be attached relative to the length of the string or segment. Distances shown are in meters.

String length (m)	100	200	300	400	500	600	700	800	900	1000
Max. no. modules	32	25	17	12	10	8	7	6	5	5

For further information:

InfoByte AG
Binzenholzstrasse 451
CH-5704 Egliswil

Switzerland

Tel. +41 (0)62 769 87 00
Fax +41 (0)62 769 87 90

info@infocontrol.com

Visit our Website
www.infocontrol.com

Visiting us?



Egliswil is located about 30 minutes from Zürich Airport direction Bern/Basel.

Copyright notice:

Website and content: Copyright 2001, 2002 INFOBYTE AG*Microsoft is a trademark from Microsoft Incorporation *INFOCONTROL is a trademark from Infobyte AG.

Technical specifications are subject to change without prior notice.